

Corporate Communications

CeramTec corporate contact:
Christoph Hermes
Head of Communication
Phone +49 (0) 7153 611-803
E-mail: pr@ceramtec.de

Press contact echolot pr:
Barbara Geier
Phone +44 (0)7983 242 195
E-mail: geier@echolot-pr.de

Press Information

iCT: new CeramTec clamping system

Increased process reliability for machining with ceramic cutting tools

Plochingen/Southampton, 13 January 2022. Reduced complexity, enhanced performance: CeramTec's new high-performance iCT tool system features a completely revised clamping system for optimised performance. At the same time, the number of variants has been reduced to enable easier handling and greater security for customers when assigning spare parts to the tools.

Cost-effective and process-safe solution

The new iCT (innovative clamping technology) tool system is an update that replaces the S3 series of turning tools and significantly increases process reliability when machining with ceramic cutting materials. The tool system is primarily used in the automotive and supplier industry for turning mass-produced cast iron components where high-performance ceramics are used for fast and highly productive machining. In recent years, the cutting speeds have increasingly gone up, placing higher demands on clamping systems.

Corporate Communications

CeramTec corporate contact:
Christoph Hermes
Head of Communication
Phone +49 (0) 7153 611-803
E-mail: pr@ceramtec.de

Press contact echolot pr:
Barbara Geier
Phone +44 (0)7983 242 195
E-mail: geier@echolot-pr.de

Press Information

Innovative all-in-one solution for complex requirements

"In this sector, CeramTec acts as a system supplier, i.e. we supply the turning tool together with the machining technology as an all-in-one solution," says Johannes Schneider, Senior Product Manager Cutting Tools at CeramTec. "Brake discs are one of the core components we offer cutting solutions for, an area in which we have a high level of expertise. With the new iCT system, we provide turning tools with significantly increased performance as well as a reduced inventory of spare parts, which makes it easier to handle for our customers." The latter includes that there is only one clamping screw type of the high-strength class 12.9 for all iCT clamping fingers as well as only one screw size for all different shims. The clamps are also available in different material versions up to a full hard metal variant and can thus be optimally adapted depending on the use case. The different sizes come in different colours, so that assigning them to the right tool is made easy. The risk of confusion is minimised and process reliability increases.

The iCT clamping system is available for all common insert types and their different applications, including smooth to heavily interrupted cuts, finishing turning in a smooth cut and rough turning under rough operating conditions. The iCT system supports a wide range of clamping types, including smooth and center hole clamping systems.

ENDS

Corporate Communications

CeramTec corporate contact:
Christoph Hermes
Head of Communication
Phone +49 (0) 7153 611-803
E-mail: pr@ceramtec.de

Press contact echolot pr:
Barbara Geier
Phone +44 (0)7983 242 195
E-mail: geier@echolot-pr.de

Press Information

Notes to the Editor

Images:



Caption: New high-performance clamping system iCT for all common insert types and their applications

Copyright: CeramTec GmbH

Corporate Communications

CeramTec corporate contact:
Christoph Hermes
Head of Communication
Phone +49 (0) 7153 611-803
E-mail: pr@ceramtec.de

Press contact echolot pr:
Barbara Geier
Phone +44 (0)7983 242 195
E-mail: geier@echolot-pr.de

Press Information

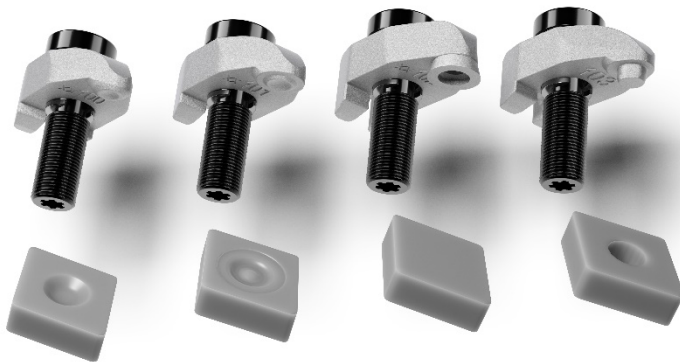

Caption: A cost-effective and process-safe solution, the new iCT tool system from CeramTec

Copyright: CeramTec GmbH

About CeramTec GmbH

CeramTec is a world-leading manufacturer of technical ceramics and is specialised in the development, manufacturing and sale of parts, components and products made from ceramic materials. With over a century of developmental and production experience, CeramTec is a global leader in the manufacturing of advanced ceramics and engineers these materials for use in a wide variety of applications. Advanced ceramics from CeramTec are used in a range of industries, including medical engineering, the automotive industry, electronics, energy and environmental engineering, as well as equipment and mechanical engineering. The current portfolio comprises well over 10,000 products, components and parts made from technical ceramics, along with a wide variety of ceramic materials.

Corporate Communications

CeramTec corporate contact:
Christoph Hermes
Head of Communication
Phone +49 (0) 7153 611-803
E-mail: pr@ceramtec.de

Press contact echolot pr:
Barbara Geier
Phone +44 (0)7983 242 195
E-mail: geier@echolot-pr.de

Press Information

With production sites and subsidiaries in Europe, the UK, America and Asia, CeramTec maintains its presence around the globe as a manufacturer and supplier. The company is headquartered in Plochingen, near Stuttgart. In 2019, CeramTec generated over €620 million in revenues. CeramTec employs more than 3,500 staff worldwide, around 2,000 of which are in Germany.

CeramTec GmbH
CeramTec-Platz 1-9
73207 Plochingen
Germany

CeramTec UK Limited
Antelope Park, Bursledon Road
Thornhill, Southampton
Hampshire, SO19 7TG
United Kingdom

www.ceramtec.com
www.ceramtec.com/linkedin
www.ceramtec.com/twitter
www.ceramtec.com/youtube